



Westside Energy

ALDINGA SCHOOL BUILDING G



GRID CONNECTED PV SYSTEM USER MANUAL



CLEAN ENERGY COUNCIL
APPROVED
SOLAR
RETAILER

1. Installation & Contact Details	3
2. Introduction	4
2.1 Installation	4
2.2 Limitation of Liability	4
2.3 Grid Connection	4
3. PV System Operation	5
4. Shutdown Procedure	6
5. Start-Up Procedure	7
6. Earth Fault Alarm	8
7. Correct System Operation	8
8. System Description	9
8.1 Solar PV Modules.....	9
8.2 Mounting Frame.....	9
8.3 Inverter.....	9
8.4 DC Isolators.....	9
8.5 Smart Meter.....	9
9 System Maintenance	10
9.1 Maintenance Schedule	11
10 Warranty Information	12
10.1 Warranty Statement.....	12
10.2 Manufacturers Warrantees	13
Appendix A – System Production Estimate	15
A1 Helioscope Production Estimate.....	15
Appendix B - System Wiring Diagram	16
B1 ALDINGA PV SYSTEM WIRING DIAGRAM	16
B2 SOLARTUNE PV-DB WIRING DIAGRAM.....	17
Appendix C – System Configuration Diagram	18
ALDINGA BUILDING G SOLAR PANEL LAYOUT DRAWING.....	18
Appendix D – Manufacturers Data Sheets	19
D1. SOLAR PV MODULES	19
D2. MOUNTING FRAME	19
D3. INVERTER	20
D4. ZJ BENNY DC ISOLATORS.....	21
D5. Wattwatchers Auditor 6M Smartmeter D5.1 Wattwatchers 3RM Smartmeter	21
Appendix E – Design and Commissioning Documentation	22
E1. STRUCTURAL ENGINEERING REPORT	22
E2. ELECTRICAL CERTIFICATE OF COMPLIANCE.....	22
E3. INSTALLATION COMMISSIONING SHEET	23
E3.1 Commissioning Sheet Inverters 1 & 2 - Strings 1 – 6.....	23
E3.2 Commissioning Sheet Inverters 3 & 4 - Strings 7 – 12.....	23
E4 - SAPN Network Protection Settings	24

1. Installation & Contact Details

Supplier 	Westside Energy (SA) Pty Ltd, 11-13 West Thebarton Road, Thebarton SA 5031 PH: 08 8451 2120 EMAIL: info@westsideenergy.com.au WEBSITE: http://www.westsideenergy.com.au ABN: 15 617 819 271
System Type Panel Type Number of Panels Inverter Type Mounting System	New 150.3 kWp Grid Connected PV System Longi 450 LR4-72HPH 450M 334 Sungrow SG30-CX Clenergy PV-ezRack – Tin Fix
Customer Site Address	Tyron Electrical 7 Dalgleish St, Thebarton SA 5031 (08) 8152 0696 Email: admin@tyrone.com.au Aldinga School Port Rd, Aldinga SA 5173
Installer 	Corey Evans Evans Electrical / Exceed Solar Telephone: 0433972308 ABN: 31 616 237 828 Email Address: corey@evanselectrical.com.au CEC Accreditation Number: A9548718 Electrical Licence Number: PGE261953

2. Introduction

Congratulations on your decision to use Westside Energy for the supply and Installation of your Photovoltaic (PV) System. Your choice to install this system will result in the reduction of greenhouse emissions and provide a reduction in CO2 emissions, as well as providing cost savings and improvements to your energy consumption.

This manual is designed to ensure that you are provided with the necessary details relating to the components that make up your system, their maintenance requirements, and their safe operation. Please read this manual carefully and keep it in a safe place for future reference.

2.1 Installation

Generally, by the time you are reading this manual, our installers will have completed the installation in accordance with the required Australian Standards, Clean Energy Council Guidelines and Manufacturers requirements. They will have tested, commissioned, and made all connections to the electricity grid, to enable you to safely operate your PV System.

Questions?

Please read carefully though the information contained in this manual. If you have any questions relating to the operation of your PV System or require any assistance, the contact details for Westside Energy and the Installer of your PV System have been provided at the beginning of this manual.

2.2 Limitation of Liability

The information contained in this manual, and all other information or advice provided by Westside Energy PTY LTD in connection with the purchase, installation, use, and service of Solar Power generation, is given in good faith. Westside Energy PTY LTD will not be liable for any person for any inaccuracy or omission in the information arising through or any actions that are the fault of Westside Energy PTY LTD, either directly or indirectly.

Westside Energy PTY LTD and suppliers included shall not be held responsible for damages of any kind, including without limitation bodily harm, injury and property damage, relating to module handling, system installation, or compliance or non-compliance with the instructions set forth in this manual.

2.3 Grid Connection

In South Australia, the connection of the PV System to the Electricity Grid is coordinated with both SA Power Networks and your Electricity Retailer.

The coordination of this connection is generally completed by Westside Energy and our installers; however, you will need to ensure that your agreement to generate electricity and subsequent feed in and rebate arrangements have been agreed and finalised, with your nominated electricity retailer. If you require any assistance with this please contact Westside energy and we will be happy to assist.

3. PV System Operation

The PV System installed for you, operates under these same basic principles regardless of its size or type.

Your Solar PV system is designed to automatically convert light from the sun to electricity. The solar panels are connected in series, creating voltages of up to 1000V DC, which is converted to 400V AC by your inverter. This electricity is then fed into your household or business switchboard. The converted power will then flow to the household /business loads and appliances.

How solar panels work

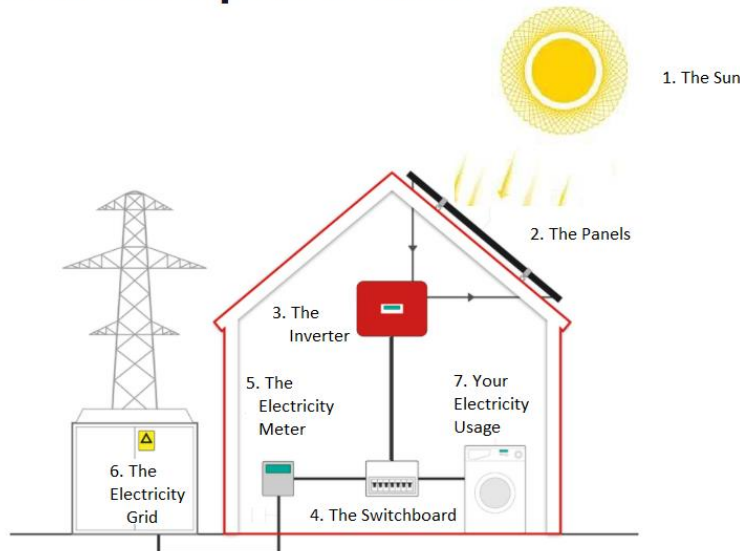

If more power is produced than what is consumed, the excess power will flow back into the grid through the meter. If more power is required than what the Solar PV system can produce, the balance is made up from the grid and is recorded by the meter. (Note: Some systems are limited in their export amounts by the electricity retailer and supply authority, these systems may not feed electricity back into the grid)

The solar system generates electricity in proportion to the amount of sunlight it receives on the solar modules and the module temperature. The peak power generation is on a clear cool day when the sun is at a perpendicular angle to the solar panels.

There will always be variance in the amount of electricity produced by the solar panels due to clouding, soiling of the panels, shading from any vegetation and a variation in the solar angles throughout the year. The solar panels will not produce and energy at night but are still able to produce a good output on cloudy and overcast days.

Your PV System will not produce any energy at night.

- [1. The Sun](#)
Energy (Light) is produced by the Sun even on cloudy days.
- [2. The Panels](#)
The PV Cells which make up the Panels convert the light into DC electricity.
- [3. The Inverter](#)
The Inverter converts the DC electricity produced by the Panels into AC Electricity.
- [4. The Switchboard](#)
The AC Electricity is distributed to either your appliances (Your Electricity Usage) or back into the Electricity Grid via The Switchboard.
- [5. The Electricity Meter](#)
The amount of energy you produce and the amount of energy you use is recorded by the Electricity Meter.
- [6. The Electricity Grid](#)
The energy you do not use is usually exported to the Electricity Grid. The energy you require that is not produced by your PV System is imported from the Electricity Grid.
- [7. Your Electricity Usage](#)
This is the electricity you require to run your home or business and is a combination of Electricity Produced by your PV System, with any shortfall made up by electricity for the Electricity Grid.

4. Shutdown Procedure

WARNING: The Shutdown procedure must be followed in the order it is shown to ensure safety and reliability of the equipment. Failure to follow the correct sequence may result in damage to your system.

There is a label that is placed on or adjacent to your inverter that lists the correct procedure for shutdown.

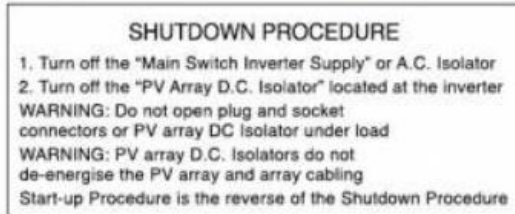

The steps are simple and are as follows:



1. Turn OFF the Main Switch Inverter Supply or AC Isolator.

This switch is adjacent the inverter and labelled as below:



If there are more than 1 inverters installed, as in larger systems, they will be labelled accordingly the procedure must be followed for each inverter.



OR



1a. Turn OFF the Main Switch Inverter Supply.

This switch is located in the Main Switchboard and labelled:



Either the Main Switch Inverter Supply and / or the Inverter AC Isolator(s) need to be turned off.



2. Turn OFF the PV Array DC Isolator.



Once you have Isolated the Main Switch Inverter Supply or AC Isolator and the

PV Array DC Isolator the system is shut down.

5. Start-Up Procedure

WARNING: The Start-up procedure must be followed in the order it is shown to ensure safety and reliability of the equipment. Failure to follow the correct sequence may result in damage to your system.

The Start-Up Procedure is a reverse of the Shutdown Procedure.

The steps are simple and are as follows:



1. Turn ON the PV Array DC Isolator.

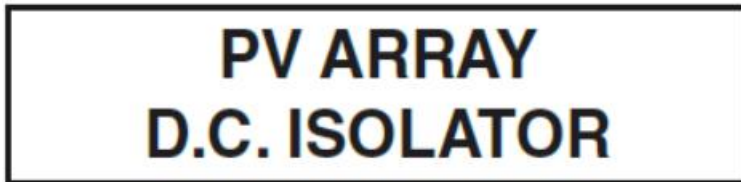

2. Turn ON the Main Switch Inverter Supply (If it has been switched off).

This switch is in the Main Switchboard and labelled:



3. Turn ON the AC Isolator.

This switch is adjacent the inverter and labelled as below:



If there are more than 1 inverters installed, as in larger systems, they will be labelled accordingly the procedure must be followed for each inverter.



Once you have switched on the DC and AC Supplies in the order shown, the system will commence its start-up sequence and after a short time the system will be operational.

6. Earth Fault Alarm

An Earth Fault in the system is a potentially dangerous situation and for your protection your inverter is equipped with a detection system, that will provide an alarm in the event of an earth fault on the system.

The fault will be notified in one of the following ways:

- A message on the inverter screen indicating an Earth Fault.
- An audible alarm from the inverter.
- A red “Earth Fault Alarm” light on the inverter.
- An email alert (where the inverter is equipped).

In the event of an Earth Fault Alarm, shut down the system as described in Section 4 - Shutdown Procedure in this manual and contact Westside Energy.

Do not re-start the system until it has been inspected and the fault has been repaired by a Westside Energy installer or representative.



7. Correct System Operation

To ensure that your system is operating correctly, after ensuring that the system Start-Up procedure has been followed as outlined in Section 5 of this manual, check that your inverter is operating and has no error lights or alarm indications. Different inverters provide indication of operation in a number of ways, eg: Green Indicator Light.

Please check the documentation provided for your inverter to ensure that the inverter is operating correctly and ensure that you check the operation in the middle of the day, in full sun light.

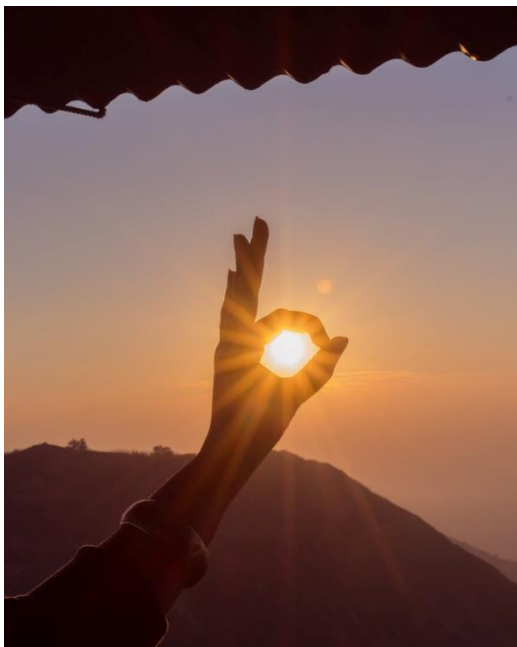

If the system does not appear to be operating, eg: No lights, blank screen, error message etc, check that all isolators are switched on as per Section 5.

Shutdown and restart the inverter by following the Section 4 Shutdown procedure and then following the Section 5 Start-up Procedure.

Please note any error lights or messages displayed on the inverter screen and consult your inverter manual for details.

If you have any difficulties or see any error messages that cannot be rectified, please contact Westside Energy and we will assist you with identifying and rectifying any issues you may encounter.

8. System Description

Your PV System is made up of the following major components. The manufacturers data sheets for these items are included in [Appendix D](#)

8.1 Solar PV Modules.

MANUFACTURER	QTY	RATING	PART#
LONGI	334	450W	LR4-72HPH-450M

The Solar PV Modules, commonly referred to as Solar Panels convert light from the sun into DC energy. The quantity of modules varies to make up different sized systems. The PV Modules are connected together in Series and Parallel Arrays to provide the necessary Voltage and Current required to generate electricity. The wiring configuration for the PV modules is shown in [Appendix D](#) of this Manual.

8.2 Mounting Frame.

MANUFACTURER	QTY	RATING	PART#
CLEENERGY	As Required	N/A	PV-ezRack® SolarRoof™

An Engineered Mounting System is used to secure the Solar PV Modules to your roof. It is designed to ensure that the panels are securely mounted and withstand all weather conditions associated with the area of installation of the panels. Where necessary, a structural engineering certificate is provided for any non-standard or tilt frame systems installed. The engineering Certificate (If required) is provided in [Appendix E](#) of this manual.

8.3 Inverter.

MANUFACTURER	QTY	RATING	PART#
SUNGROW	4	29.9kVA	SG30CX

The DC Electricity produced by the PV Modules is converted to AC Electricity to power appliances within the home or business and also to export to the National Electricity Grid where exporting of electricity is configured. Details are included in the manufacturers data sheets in [Appendix D](#) of this manual. Safe operation and shutdown of the inverter is described in [Sections 4 & 5](#) of this manual.

8.4 DC Isolators.

MANUFACTURER	QTY	RATING	PART#
ZJ BENNY	12	32A	BYH-32

DC Isolators are used to isolate the DC supplies from the PV Modules.

The AC Isolator isolates the AC supply to and from the inverter

8.5 Smart Meter.

MANUFACTURER	QTY	CT RATING	PART#
Wattwatchers	1	200A	Auditor 6M + 3SW
Wattwatchers	1	3000A	Auditor 3RM

The Smart Meter (Where installed) provides data on Generation/Production as well as electricity usage to the user.

9 System Maintenance

It is recommended that solar panel systems should only be inspected and maintained by a licenced electrician or Clean Energy Council-accredited solar panel system installer.

WARNING: All maintenance tasks involving electrical equipment should be performed by a licenced and qualified electrician.

WARNING: Care should be taken when Working at Heights. Ensure that any work performed on roof tops or areas where there is a risk of falling is only performed by experienced and qualified personnel. Details regarding safe working at heights procedures can be obtained from [Safework SA](#).

Maintaining your solar panel system involves much more than simply cleaning your solar panels. Regular maintenance of your solar panel system should ensure:

- solar panels are clean, secure and free of defects
- no parts have deteriorated/corroded
- vents are free of debris
- switches do not have any defects
- wiring has not been damaged/has not deteriorated
- electrical checks to ensure all components are operating as intended
- confirming fittings and cables are securely attached
- reviewing the inverter display panel for recorded faults
- checking that access to the isolator switches has not been impeded, and/or
- making sure the emergency procedures for shutdown and isolation are clearly displayed.



9.1 Maintenance Schedule

The following inspections should be completed as noted

Component	Maintenance required	Frequency	Comments
Site	Check cleanliness and accumulation of debris under panels	Quarterly	Clean as required
	Check for shading of panels		Trim tree branches as required
	Check for Shading	Quarterly	
PV Modules	Check Cleanliness	Annually	Clean as required
	Check for defects including fractures, discoloration, moisture penetration and corrosion	Annually	Replace if defective
	Check bypass diodes	Annually	Replace if defective
Wiring	Verify integrity of conduits and cabling	5 years	Replace if defective
	Check Junction Boxes and Isolators for water egress	Yearly	Clean or replace if faulty
	Check terminals for tightness or corrosion. Ensure clamps and ties have not degraded or failed		Tighten loose terminals Replace if faulty
Electrical	Measure Open Circuit Voltage	Yearly	Record V
	Measure Short Circuit Current	Yearly	Record A
Protective Devices	Check integrity of fuses Check operation of CB's and RCD's Check Isolator Operation	Yearly	Repair / Replace if faulty
Mounting System	Verify tightness of bolts and fixings	Yearly	Tighten,
	Inspect for corrosion	5 Years	Clean/Repair as necessary

10 Warranty Information

Your PV System is covered by both Installation and manufacturers warranties. Please read the warranty documents an if you have any questions, contact Westside energy for further clarification.

10.1 Warranty Statement



WARRANTY POLICY STATEMENT February 2018

Westside Energy (SA) Pty Ltd warrants the energy systems that are installed under Westside Energy work orders. It is Westside Energy's objective to treat all customers fairly and ensure the products that are supplied and installed meet their design objectives. As such, Westside Energy offers:

- Installation warranties

Westside Energy warrants all installations based on the agreement with the individual customer. The installation warranty covers the workmanship to install the equipment or system purchased by the customer. In the event of a fault, Westside Energy will act to fix or replace (subject to product warranty requirements) within the term of the warranty.

and,

- Product warranties

Major equipment supplied and installed by Westside Energy carries a manufacturer's warranty. The terms and conditions of manufacturer's warranties differ and will be provided to each customer.

Westside Energy manufactured equipment is provided and installed with a 5-year product warranty where in the case of a fault, Westside Energy will cover the costs of repair and replacement, provided it is determined the equipment and system was being used for the purposes it was designed and within the operating parameters.

Neither the installation or product warranty will cover:

- Existing installations that Westside Energy is required to connect to for overall use of the equipment or system;
- Normal wear and tear;
- Any malicious damage or abuse;
- Damage caused by animals, people, extreme weather conditions, "acts of God", improper voltage or power surges beyond Westside Energy's reasonable control;
- Corrosion, oxidisation, discolouration by mould or similar;
- Alterations made to existing infrastructure to support the installation; or
- Any damage of any kind that was not reasonably foreseeable or could not be expected.

Warranties are valid only if the work has been completed and all payments have been received by Westside Energy. Product warranty timelines are based on the manufacturing date and not the installation date. All warranties are transferrable by the original customer to any subsequent owner provided that the equipment and system is being used for the purposes it was designed and within the operating parameters.

Customers are required to notify Westside Energy in the event of a problem with an installation and provide Westside Energy adequate time to remedy the issue free of charge.

Customers are to be informed of the warranties provided by Westside Energy and the products installed by Westside Energy. Products that do not meet with the above warranty provisions will not be installed by Westside Energy unless specifically required and acknowledged by a customer.

Wayne Irvine - Director

Allan Sage – Director

Chris Bull – Director

10.2 Manufacturers Warrantees

INVERTER WARRANTY

[10.2.1-SUNGROW_Inverter_Warranty](#)



SOLAR PANEL WARRANTY

[10.2.2-Longi Australia Warranty](#)



SOLAR PANEL WARRANTY CLAIM DETAILS

[10.2.3-Longi Australia Warranty Claim Details](#)



MOUNTING FRAMES WARRANTY

[10.2.4-Cleenergy Standard Warranty](#)



Appendix A – System Production Estimate

A1 Helioscope Production Estimate



Annual Production Report produced by Peter Smith

Aldinga Building G - AS Built Aldinga Superschool, Port Rd, Aldinga SA 5173, Australia

Report

Project Name	Aldinga Superschool
Project Address	Port Rd, Aldinga SA 5173, Australia
Prepared By	Peter Smith chris.bull@westsidegroup.com.au

System Metrics

Design	Aldinga Building G - AS Built
Module DC Nameplate	150.3 kW
Inverter AC Nameplate	119.6 kW Load Ratio: 1.26
Annual Production	204.7 MWh
Performance Ratio	79.5%
kWh/kWp	1,361.9
Weather Dataset	TMY, 10km Grid, meteonorm (meteonorm)
Simulator Version	F32791ae32-2bc0e40f0c-8e3c28cfc5-f831c3d7b8

Project Location

Monthly Production

Sources of System Loss

Annual Production

	Description	Output	% Delta
Irradiance (kWh/m ²)	Annual Global Horizontal Irradiance	1,780.3	
	PQA Irradiance	1,713.5	-3.7%
	Shaded Irradiance	1,705.7	-0.4%
	Irradiance after Reflection	1,632.8	-4.3%
	Irradiance after Soiling	1,600.1	-2.0%
	Total Collector Irradiance	1,600.1	0.0%
Energy (kWh)	Nameplate	240,648.7	
	Output at Irradiance Levels	239,177.3	-0.6%
	Output at Cell Temperature Derate	218,566.2	-8.6%
	Output After Mismatch	210,950.7	-3.5%
	Optimal DC Output	209,835.7	-0.5%
	Constrained DC Output	209,667.6	-0.1%
	Inverter Output	205,723.4	-1.9%
	Energy to Grid	204,694.8	-0.5%
Temperature Metrics			
	Avg. Operating Ambient Temp	17.1 °C	
	Avg. Operating Cell Temp	33.9 °C	
Simulation Metrics			
	Operating Hours	4575	
	Solved Hours	4575	

Condition Set

Description	Condition Set 1											
Weather Dataset	TMY, 10km Grid, meteonorm (meteonorm)											
Solar Angle Location	Meteo Lat/Lng											
Transposition Model	Perez Model											
Temperature Model	Sandia Model											
Temperature Model Parameters	Rack Type	a	b	Temperature Delta								
	Fixed Tilt	-3.56	-0.075	3°C								
	Flush Mount	-2.81	-0.0455	0°C								
Soiling (%)	J	F	M	A	M	J	J	A	S	O	N	D
	2	2	2	2	2	2	2	2	2	2	2	2
Irradiation Variance	5%											
Cell Temperature Spread	4° C											
Module Binning Range	-2.5% to 2.5%											
AC System Derate	0.50%											
Module Characterizations	Module	Uploaded By	Characterization									
	LR4-72HPH-450(2019) (Long Solar)	Folsom Labs	Spec Sheet Characterization, PAN									
Component Characterizations	Device	Uploaded By	Characterization									
	SG30CX (Sungrow)	Folsom Labs	Default Characterization									

Appendix B - System Wiring Diagram

B1 ALDINGA PV SYSTEM WIRING DIAGRAM

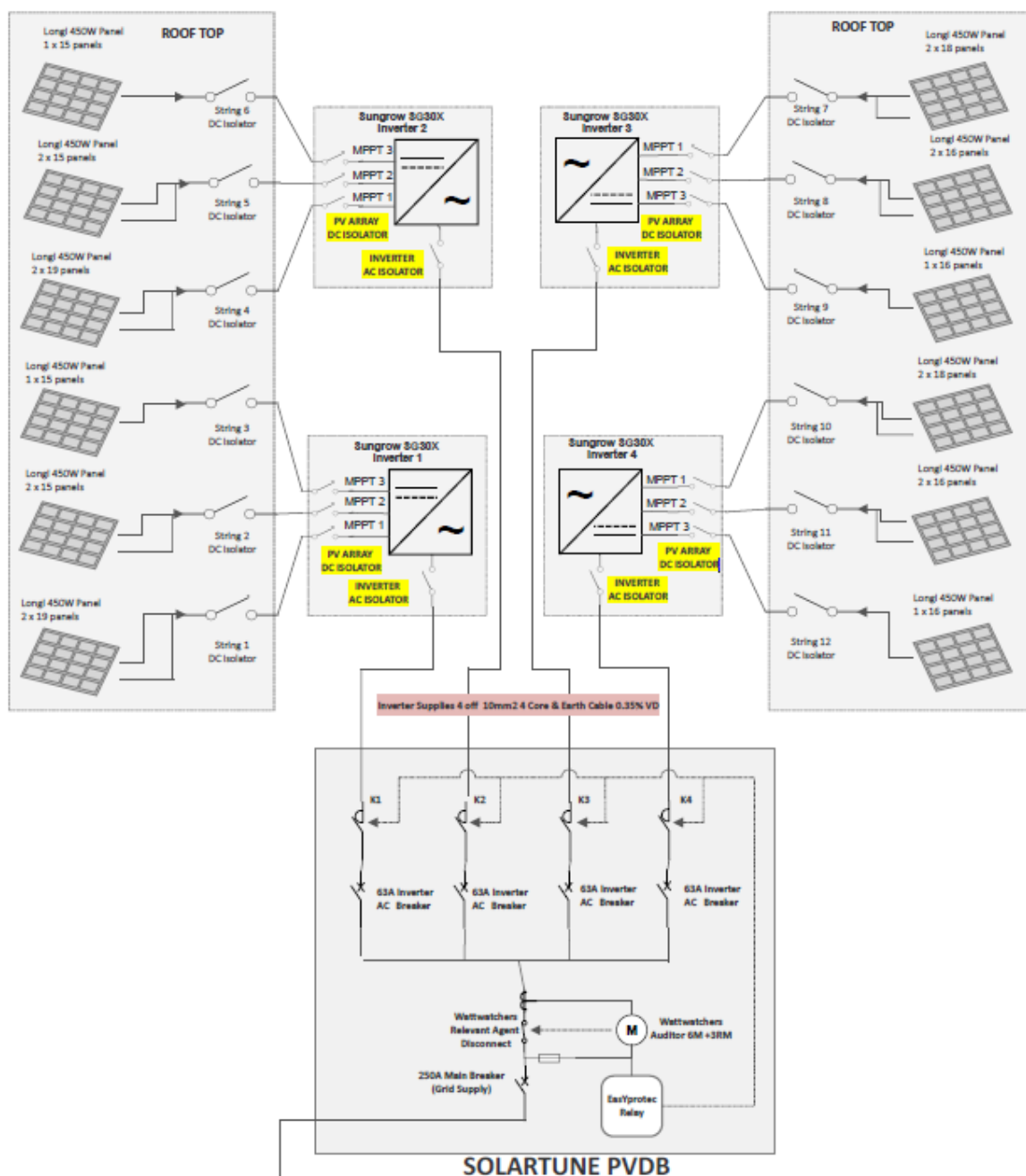

B2 SOLARTUNE PV-DB WIRING DIAGRAM

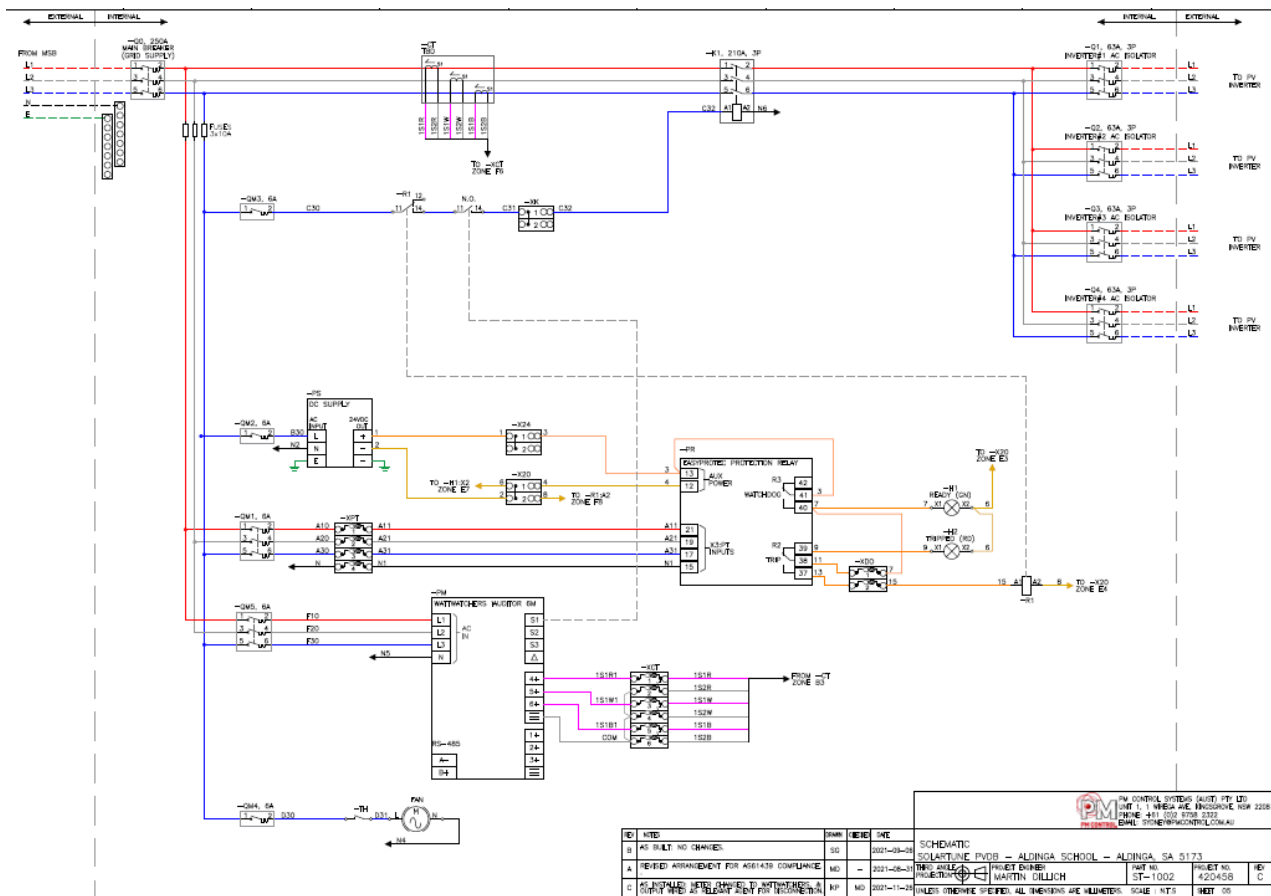

Appendix C – System Configuration Diagram

ALDINGA BUILDING G SOLAR PANEL LAYOUT DRAWING

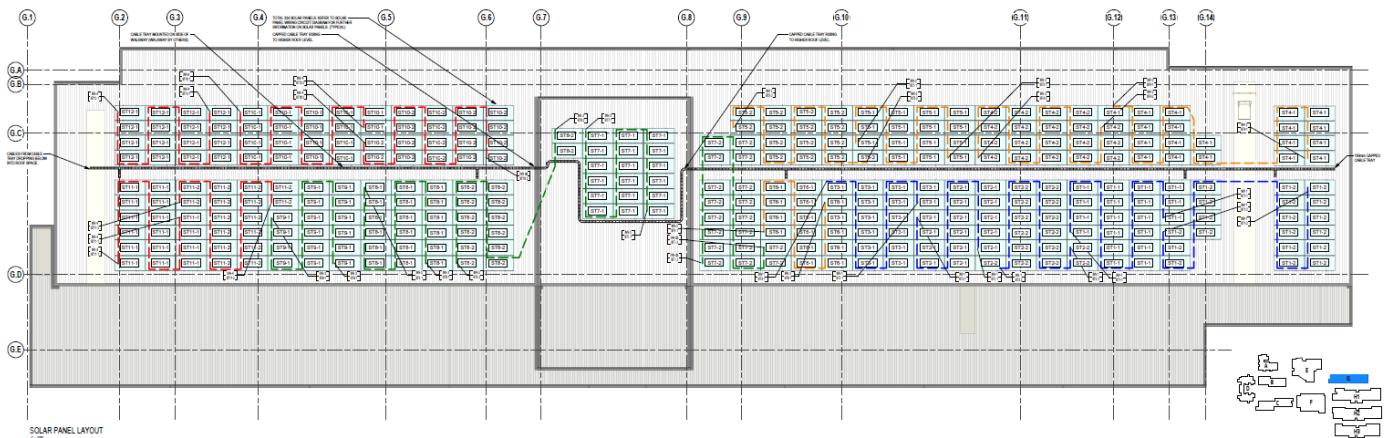

Appendix D – Manufacturers Data Sheets

D1. SOLAR PV MODULES



D2. MOUNTING FRAME



D3. INVERTER

[D3. Sungrow SG30X Inverter Data Sheet](#)



[D3.1 Sungrow SG30X Inverter User Manual](#)



D4. ZJ BENNY DC ISOLATORS



D5. Wattwatchers Auditor 6M Smartmeter

D5.1 Wattwatchers 3RM Smartmeter



Appendix E – Design and Commissioning Documentation

E1. STRUCTURAL ENGINEERING REPORT



E2. ELECTRICAL CERTIFICATE OF COMPLIANCE



E3. INSTALLATION COMMISSIONING SHEET

[E3.1 Commissioning Sheet Inverters 1 & 2 - Strings 1 – 6](#)



[E3.2 Commissioning Sheet Inverters 3 & 4 - Strings 7 – 12](#)





Attachment 3:

(a) Inverter settings for PVI and/or ESI systems

PROTECTION	TYPE	SETTING (e.g. 230/400V)	TRIP DELAY TIME (SEC)	MAXIMUM DISCONNECTION TIME (SEC)
Over Voltage 1	V	115% Nominal Voltage (265V)	1	2
Over Voltage 2	V	120% Nominal Voltage (275V)	-	0.2
Under Voltage 1	V	78% Nominal Voltage (180V)	10	11
Under Voltage 2	V	30% Nominal Voltage (70V)	1	2
Sustained over-voltage ¹	V	112% Nominal Voltage (258V)	-	-
Over Frequency	f	52 Hz	-	0.2
Under Frequency	f	47 Hz	1	2

(b) PVI & ESI back-up Anti-Islanding protection settings

PROTECTION	TYPE	SETTING (e.g. 230/400V)	TRIP DELAY TIME (SEC)
Over Voltage 1	V	115% Nominal Voltage (265V)	2
Over Voltage 2	V	120% Nominal Voltage (275V)	0.2
Under Voltage 1	V	78% Nominal Voltage (180V)	11
Under Voltage 2	V	30% Nominal Voltage (70V)	2
Sustained over-voltage ¹	V	112% Nominal Voltage (258V)	-
Over Frequency	f	52 Hz	2
Under Frequency	f	47 Hz	2

(c) Rate of Change of Frequency (ROCOF)

As the capacity of the Generating System is greater than 30kVA, a protection system must be installed that includes ROCOF protection. The Generating System must be capable of continuous uninterrupted operation for one of the following rate of change of frequencies:

ROCOF	DURATION
Hz/s	Sec
±4	0.25
±3	1

Sustained operation for Voltage variations (Clause 4.5.2 of AS 4777.2: 2020)

Reference	Voltage in Volts
V _{nom-max}	258

Volt-VAr response mode (Table 3.7 of AS 4777.2: 2020)

REFERENCE	VOLTAGE (e.g. 230/400V)	VAr % RATED VA
V _{V1}	90% Nominal Voltage (207V)	44% leading (sourcing VArS, 3.4%/V)
V _{V2}	96% Nominal Voltage (220V)	0
V _{V3}	104% Nominal Voltage (240V)	0
V _{V4}	112% Nominal Voltage (258V)	60% lagging (sinking VArS, 3.3%/V)

Volt-Watt response mode (Table 3.6 of AS 4777.2-2020)

REFERENCE	VOLTAGE (e.g. 230/400V)	W % RATED VA
V _{W1}	110% Nominal Voltage (253V)	100%
V _{W2}	113% Nominal Voltage (260V)	20% (11.4%/V)